

# Technical Specification

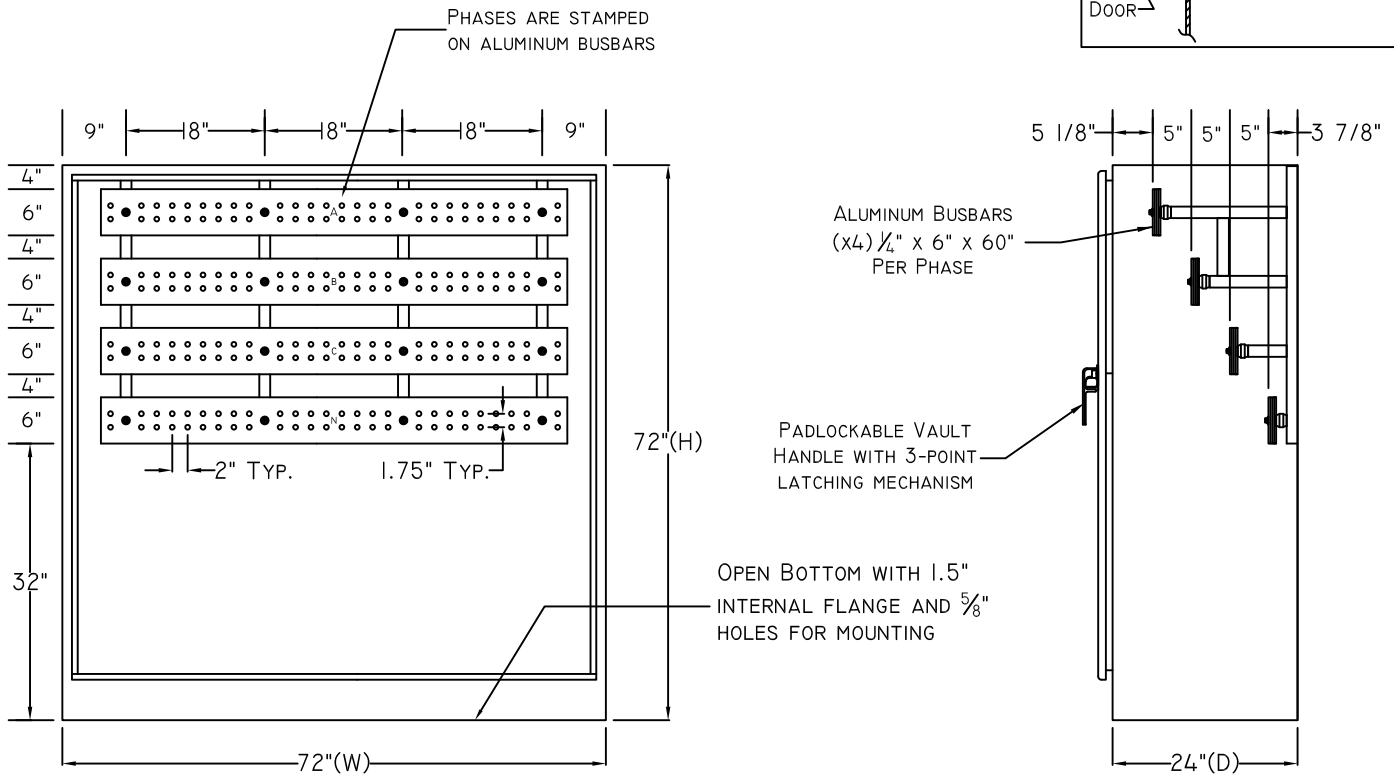
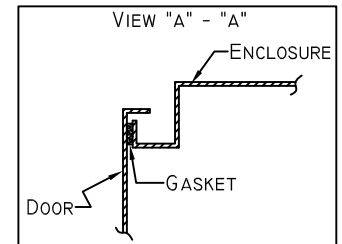

## 4000 AMP / 3 PHASE TERMINATION CABINET

- ❑ TERMINATION CABINETS ARE CONSTRUCTED WITH ALL WELDED SEAMS. MATERIAL IS GALVANNEALED SHEET STEEL CONFORMING WITH ASTM A653. FINISH IS POWDER COATED ANSI 61 GRAY.
- ❑ DOUBLE DOORS PROVIDED WITH CONTINUOUS, STAINLESS STEEL PIANO HINGES. 3 POINT LATCHING MECHANISM SUPPLIED WITH PADLOCKABLE HANDLE. BOTTOM IS OPEN WITH A 1.5" INTERNAL FLANGE AND  $\frac{5}{8}$ " HOLES FOR MOUNTING.
- ❑ BUSBARS ARE FABRICATED FROM ALUMINUM ALLOY BAR STOCK,  $\frac{1}{4}$ " THICK, 6101-T61 IN ACCORDANCE WITH ASTM B317. BUSBARS ARE PUNCHED TO ACCOMMODATE STANDARD 2 HOLE HIGH-PRESS LUGS.
- ❑ POWER TERMINATION CABINETS ARE CONSTRUCTED IN ACCORDANCE WITH UL BULLETIN #50 AND NEMA 3R SPECIFICATIONS.

DOMINION VIRGINIA POWER APPROVED PART# PPTCDV4

DWG. TITLE: 4000 AMP / 3 PHASE  
TERMINATION CABINET

DWG. NO.: P10119

MATERIAL: ASTM A653 GALVANNEALED

FINISH: ANSI 61 GRAY

NOTICE:  
THIS INFORMATION IS THE PROPERTY OF N.J. SULLIVAN CO., ANY REPRODUCTION, PUBLICATION OR DISTRIBUTION TO A THIRD PARTY IS STRICTLY FORBIDDEN UNLESS WRITTEN PERMISSIONS ARE GIVEN BY AN AUTHORIZED AGENT OF:  
N.J. SULLIVAN CO., INC.

DFTG.:	CD	DATE:	2/21/14
CHKR.:		DATE:	
REV.:		DATE:	
REV.:		DATE:	
REV.:		DATE:	

**N.J.**  
**SULLIVAN Co.**

INCORPORATED  
P.O. BOX 438, STERLING, VIRGINIA 20167  
METAL FABRICATION  
Phone: (703)-464-5944 Fax: (703)-464-5992  
www.njsullivan.com

# Technical Specification

## BOTTOM VIEW FOR FOR PARTS PPTCDV4-6

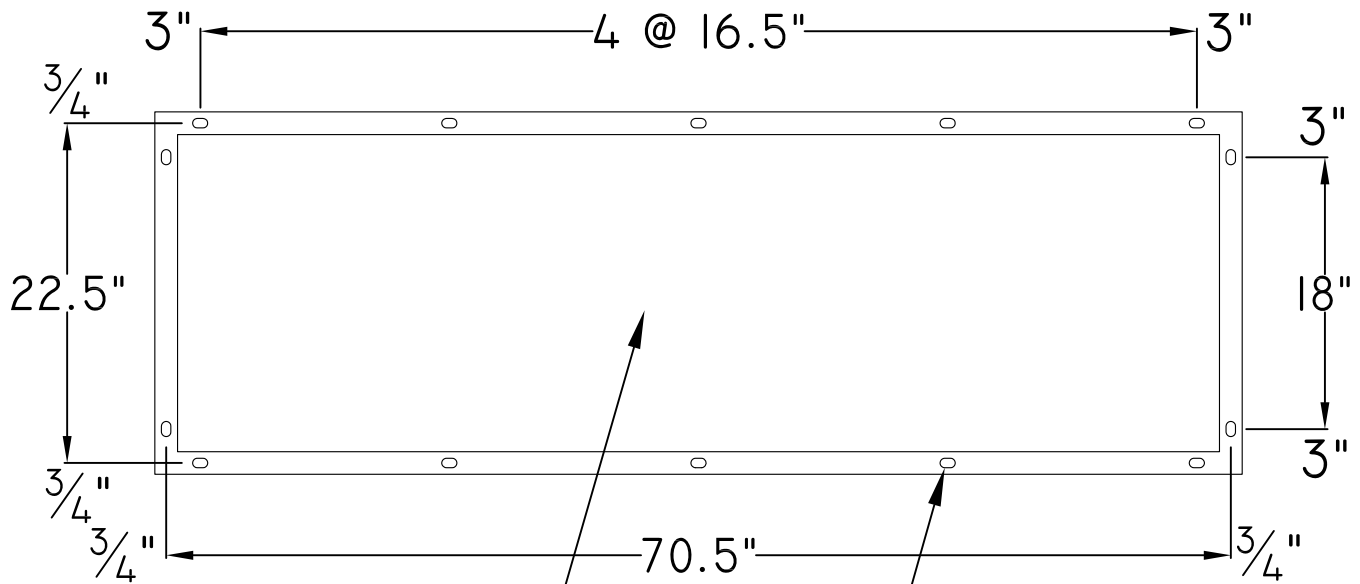

69" x 21" OPENING

1.5" INTERNAL MOUNTING  
FLANGE WITH  $\frac{5}{8}$ " x 1" SLOTS  
FOR  $\frac{1}{2}$ " $\varnothing$  HARDWARE

DWG. TITLE: MOUNTING FLANGE FOR  
PARTS PPTCDV4-6

DWG. NO.: P10122

MATERIAL: ASTM A653 GALVANNEALED

FINISH: ANSI 61 GRAY

NOTICE:  
THIS INFORMATION IS THE PROPERTY OF N.J.  
SULLIVAN CO.. ANY REPRODUCTION, PUBLICATION  
OR DISTRIBUTION TO A THIRD PARTY IS STRICTLY  
FORBIDDEN UNLESS WRITTEN PERMISSIONS ARE  
GIVEN BY AN AUTHORIZED AGENT OF:  
N.J. SULLIVAN CO., INC.

DFTG.:	CD	DATE:	2/27/14
CHKR.:		DATE:	
REV.:		DATE:	
REV.:		DATE:	
REV.:		DATE:	

**N.J.**  
**SULLIVAN Co.**

INCORPORATED  
P.O. BOX 438, STERLING, VIRGINIA 20167  
METAL FABRICATION  
Phone: (703)-464-5944 Fax: (703)-464-5992  
www.njsullivan.com