

**Pre-Approved PHICT301 Metering Busbar
Construction / 2001-3000 Amp**

PHICT301 3-Phase Metering C/T Cabinet / 2001-3000Amp / NEMA 1

- C/T cabinets are constructed with all welded seams. Material is 12Ga. galvanealed sheet steel, conforming with ASTM A-653 and Powder Coat, ANSI 61.
- Busbars are fabricated from Silver Plated Copper and aluminum alloy. (Ref. drawing # PHICT-301-3)
- Busbar supports are molded of UL recognized flame resistant fiber glass reinforced compound.
- Cabinets are provided with removable access panels top and bottom. Mid-section has hinged door for access to C/T's. Panels and door are supplied with utility seal tabs.
- PHI C/T cabinets are constructed in accordance with UL and NEMA 1 specifications & PHI drawings 7-5-0606 & 7-5-0695.
- 18" Skirt is provided with cabinet w/ screwed on cover, can be used as header box w/ additional screw on cover for top.

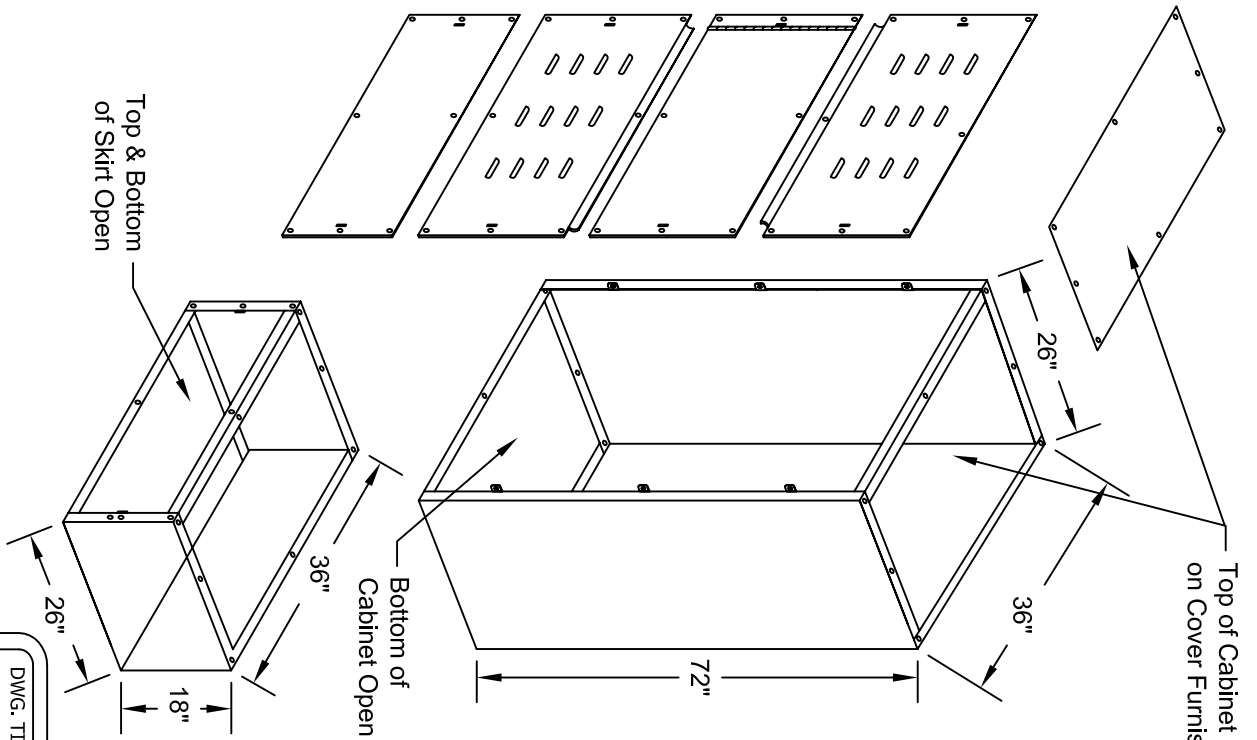

PHICT Part #	AMPERAGE RATING	ENCLOSURE			BUSSING			NO. LANDINGS	
		W	H	D	CT THRU BAR	LINE/LOAD	NEUTRAL	LINE	LOAD
PHICT151	801-1500	36"	72"	19"	CU-(2) 1/4"x 4"	AL-(2) 1/4"x 4"	AL-(1) 1/4"x 4"	8	4*
PHICT201	1501-2000	36"	72"	26"	CU-(3) 1/4"x 4"	AL-(3) 1/4"x 4"	AL-(2) 1/4"x 4"	14	14
PHICT301	2001-3000	36"	72"	26"	CU-(4) 1/4"x 4"	AL-(6) 1/4"x 4"	AL-(2) 1/4"x 4"	14	14
PHICT401	3001-4000	48"	72"	26"	CU-(4) 1/4"x 5"	AL-(6) 1/4"x 6"	AL-(2) 1/4"x 4"	14	14

Optional kit available, kit provides equal load landings as line side landings

DWG. TITLE: **3-Phase Metering CT Cabinet**
 NEMA 1 / 3000 Amp
 DWG. NO.: **PHICT-301-1**
 MATERIAL: **ASTM A653 Galvanealed**
 FINISH: **Painted Gray**

NOTICE: THIS INFORMATION IS THE PROPERTY OF N.J. SULLIVAN COMPANY. REPRODUCTION, PUBLICATION OR DISTRIBUTION TO A THIRD PARTY IS STRICTLY FORBIDDEN UNLESS WRITTEN PERMISSIONS ARE GIVEN BY AN AUTHORIZED AGENT OF: N.J. SULLIVAN CO., INC.

DFTG.: _____ CD _____ DATE: 8/16/11
 CHKR.: _____ DATE: _____
 REV.: _____ DATE: _____
 REV.: _____ DATE: _____

SULLIVAN Co.
 INCORPORATED
 P.O. BOX 438, STERLING, VIRGINIA 20167
 METAL FABRICATION
 Phone: (703)-464-5944 Fax: (703)-464-5992
 www.njsullivan.com

Pre-Approved PHICT301 Metering Busbar Construction / 2001-3000 Amp

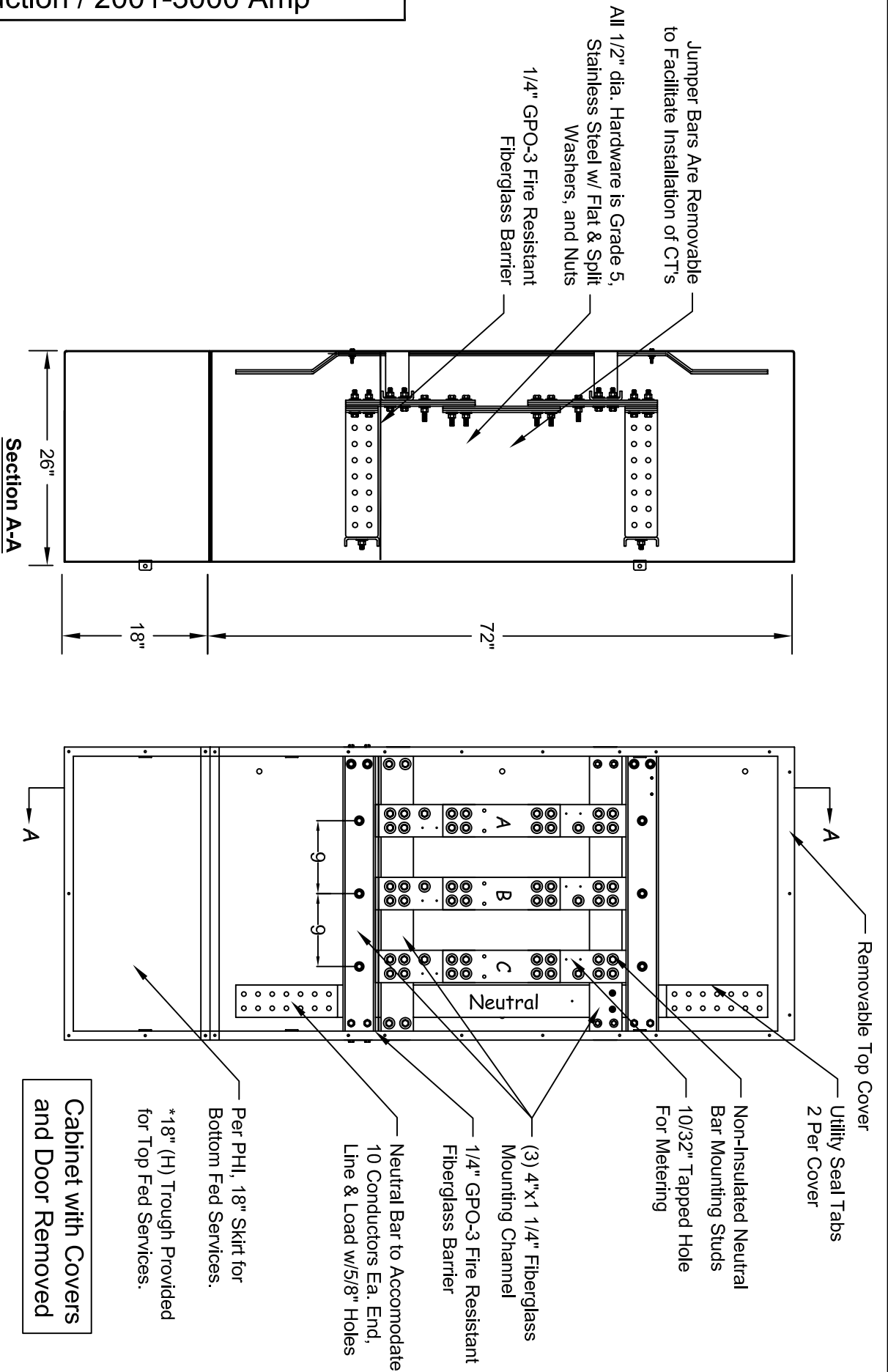

DWG. TITLE:	3-Phase Metering CT Cabinet
DWG. NO.:	PHICT-301-2
MATERIAL:	ASTM A653 Galvanealed
FINISH:	Painted Gray

NOTICE: THIS INFORMATION IS THE PROPERTY OF N.J. SULLIVAN CO. ANY REPRODUCTION, PUBLICATION OR DISTRIBUTION TO A THIRD PARTY IS STRICTLY FORBIDDEN UNLESS WRITTEN PERMISSIONS ARE GIVEN BY AN AUTHORIZED AGENT OF: N.J. SULLIVAN CO., INC.	
DFTG.:	CD
CHKR.:	DATE: 8/16/11
REV.:	DATE:
REV.:	DATE:
REV.:	DATE:

SULLIVAN Co.

INCORPORATED
P.O. BOX 438, STERLING, VIRGINIA 20167
METAL FABRICATION
Phone: (703)-464-5944 Fax: (703)-464-5992
www.njsullivan.com

**Pre-Approved PHICT301 Metering Busbar
Construction / 2001-3000 Amp**

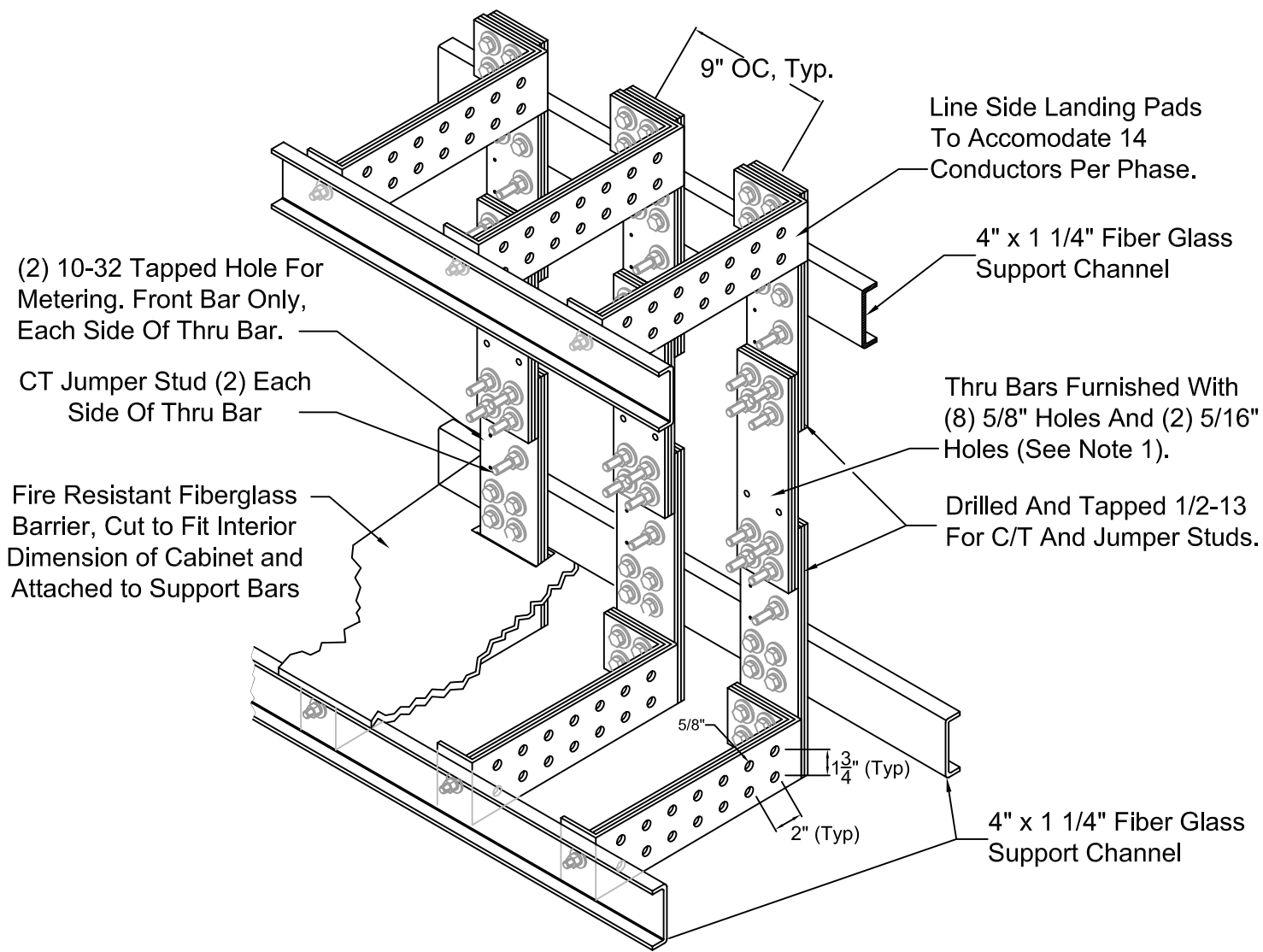

Notes:

1. **Bussing built to UL 1773 & UL 891.**
2. **Unless otherwise noted, all hardware to be stainless steel.**
3. **Line-Load & Neutral bars furnished as 1/4" thick, 6101-T61 aluminum alloy per ASTM B317.**
CT thru bars are to be 1/4" thick, silver plated copper bar.
4. **1/4" GPO-3 Fiberglass barrier mounted above 'line' landings.**

* Drawing for reference only, see chart on sheet 301-1 for proper bar & landing configurations.

DWG. TITLE:	PHI Metering Busbar Construction / 3000 Amp
DWG. NO.:	PHICT-301-3
MATERIAL:	As Noted
FINISH:	N/A

NOTICE: THIS INFORMATION IS THE PROPERTY OF N.J. SULLIVAN CO., ANY REPRODUCTION, PUBLICATION OR DISTRIBUTION TO A THIRD PARTY IS STRICTLY FORBIDDEN UNLESS WRITTEN PERMISSIONS ARE GIVEN BY AN AUTHORIZED AGENT OF: N.J. SULLIVAN CO., INC.		
DFTG.:	CD	DATE: 8/16/11
CHKR.:		DATE:
REV.:		DATE:
REV.:		DATE:
REV.:		DATE:

SULLIVAN Co.
 INCORPORATED
 P.O. BOX 438, STERLING, VIRGINIA 20167
 METAL FABRICATION
 Phone: (703)-464-5944 Fax: (703)-464-5992
 www.njsullivan.com