

REVISIONS				
ZONE	REV.	DESCRIPTION	APP'D.	DATE
1	1	INITIAL RELEASE		05/22/01

Technical Specification

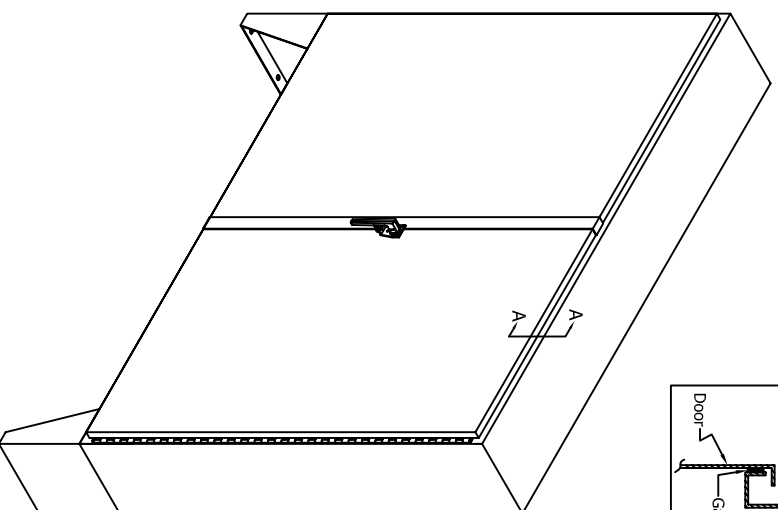
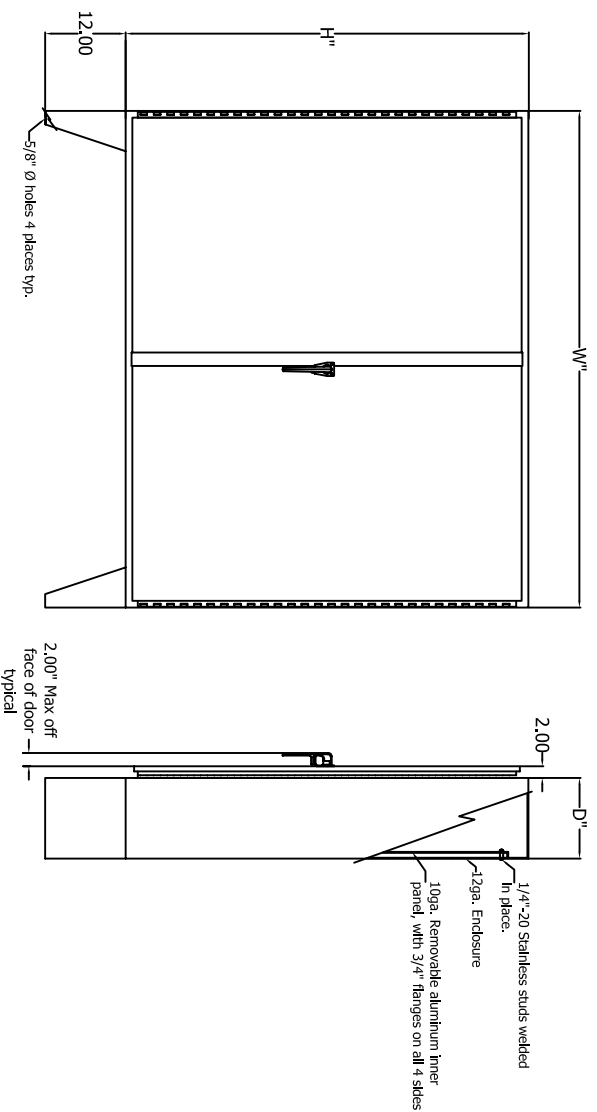

NEMA 4X Floor-Mounted 2-Door Equipment Enclosure

- Floor-mounted enclosures are constructed with all welded seams. Material is 12ga. 304 stainless steel, conforming with ASTM A240.
- Single or double doors provided with continuous piano hinges, 3-point latching mechanism supplied with either padlock or keylock handle. Stainless hardware used throughout.
- Total custom capability allows us to meet a wide range of customer needs. We can supply special sizes, shapes, holes, or cutouts.
- Floor-mounted enclosures are constructed in accordance with UL bulletin #50 and NEMA 4x specifications.

FINISH: OTHERWISE SPECIFIED:		NOTICE		N.J. SULLIVAN CO.	
DIMENSIONS ARE IN INCHES; TOLERANCES FRACTIONS DECIMALS ANGLES ± .030" ± .001" ± 0° 30'		THIS INFORMATION IS THE PROPERTY OF N.J. SULLIVAN CO. ANY REPRODUCTION, PUBLICATION OR DISTRIBUTION TO A THIRD PARTY IS STRICTLY FORBIDDEN UNLESS WRITTEN PERMISSIONS ARE GIVEN BY AN AUTHORIZED AGENT OF:		P.O. BOX 438, STEVENS, VIRGINIA 20187 METAL FABRICATION Phone: (703)-471-4544 Fax: (703)-471-0275	
MATERIAL: 304 Stainless Steel ASTM A240		DATE: 05/22/01		DWG. NO.: P10011	
FINISH: 2B		DATE: 05/22/01		REV:	
PROJ. ENG.:		DATE:		SCALE: None	
		DATE:		SHEET 1 OF 1	